



260 North Elm Street - Westfield, MA 01089
413.568.9571 fax 413.568.1178

SINGLE BOILER PRIMARY/SECONDARY/TERTIARY ZONES CONSTANT TEMPERATURE

Hydronic Piping H-13

Boiler connection Pipe Sizing
and Heat Exchanger Configuration

Heater Model	Pipe size NPS	Configurations
50-400	1 1/2"	Two Pass
420-1900	2 1/2"	Two Pass
2000-4000	3"	Two Pass
Dominator	2 1/2"	Two Pass
Futura	2 1/2"	Four Pass

- Pump
- Gate Valve
- Globe Valve
- Angle Valve
- Butterfly Valve
- Circuit Setter
- Ball Valve
- Motorized Valve
- Solenoid Operated Valve
- Self-Operated Valve
- Pressure Reducing Valve
- Check Valve
- Pressure Relief Valve
- Flow Switch
- Thermometer
- Aquastat Union
- Pressure Switch
- Gas Pressure Regulator
- Automatic Air Vent

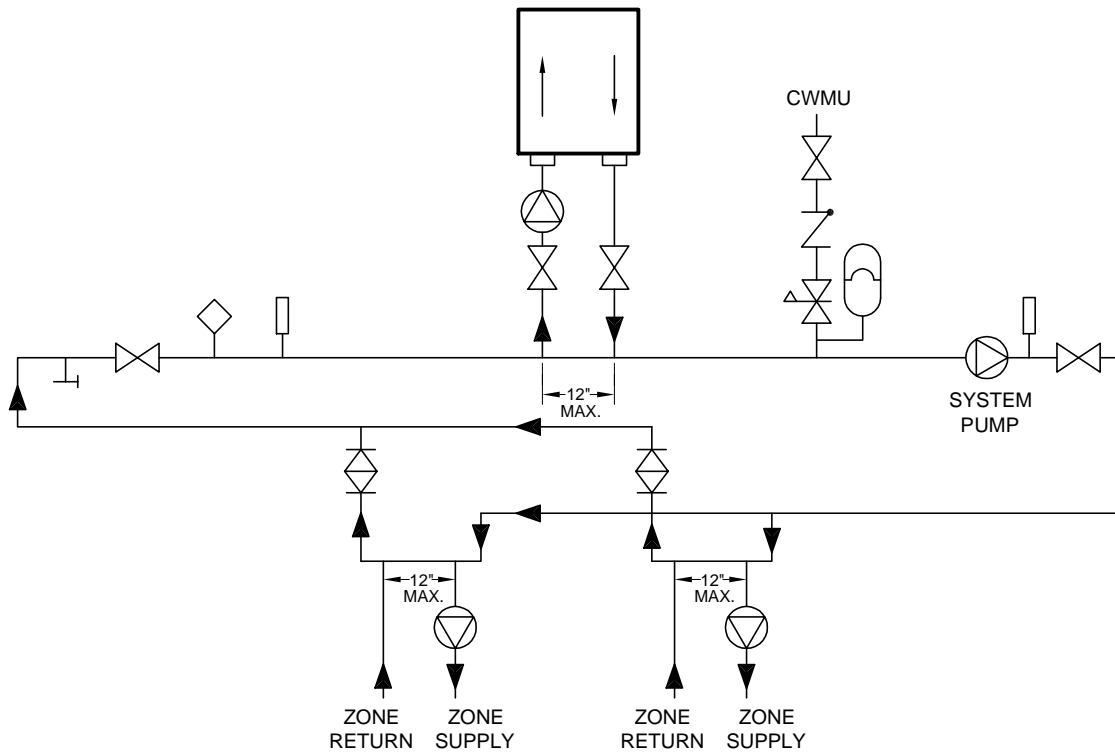

NOTES:

1. Primary/Secondary required for variable flow systems.
2. Boiler circuit piping must equal boiler connection size.
3. Boiler Pump sized to boiler design flow requirements.
4. Boiler water connection (inlet/outlet) vary per model. Verify connection orientation.
5. All boilers furnished with factory mounted outlet water temperature gauge.
6. Dotted symbols indicate optional locations.
7. Boiler Pump requires system temp Interlocks.
8. CWMU = Cold Water Make-Up.
9. Temperature sensors require field interlocks to boiler control.
10. Boiler loop to be maintained at 180°F.
11. Zone thermostats to be interlocked with boiler. Boiler to fire upon call for heat from any zone.
12. Zone piping and interlock wiring to be designed by system designer.

Notice: This drawing shows suggested piping configuration and valving.
Check with local codes and ordinances for additional requirements.