



260 North Elm Street - Westfield, MA 01089  
413.568.9571 fax 413.568.1178

# ONE HEATER TWO PASS TWO HORIZONTAL TANKS

Domestic Piping D-6

SELF BALANCING REVERSE RETURN MAKE-UP & SUPPLY

Heater connection Pipe Sizing and Heat Exchanger Configuration

Heater Model	Pipe size NPS	Configurations
50-400	1 1/2"	Two Pass
420-1900	2 1/2"	Two Pass
2000-4000	3"	Two Pass
Dominator	2 1/2"	Two Pass
Futura	2 1/2"	Four Pass

- Pump
- Gate Valve
- Globe Valve
- Angle Valve
- Butterfly Valve
- Circuit Setter
- Ball Valve
- Motorized Valve
- Solenoid Operated Valve
- Self-Operated Valve
- Pressure Reducing Valve
- Check Valve
- Pressure Relief Valve
- Flow Switch
- Thermometer
- Aquastat Union
- Pressure Switch
- Gas Pressure Regulator
- Automatic Air Vent

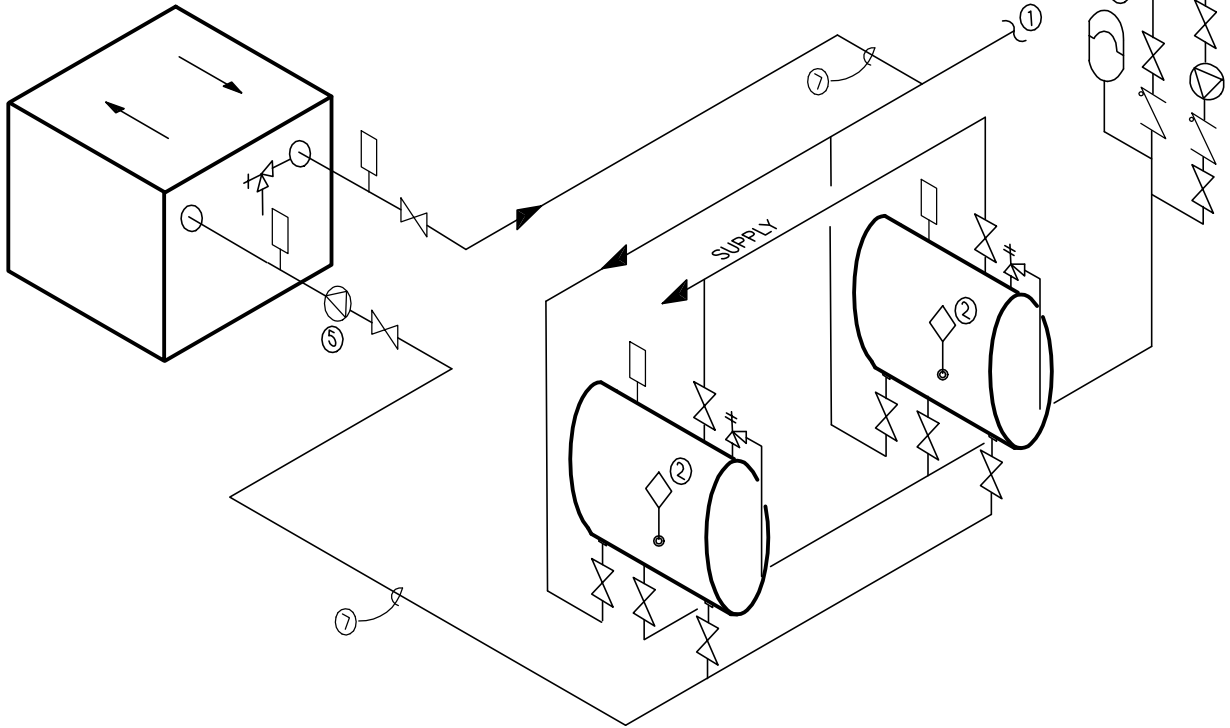

**NOTES:**

1. Optional CWMU & Recirc. line location.
  2. When using intermittent pump and pump delay, locate remote aquastat well in lower 1/3 of tank with heat sensing compound.
  3. Back flow preventer may be required, check local codes.
  4. Thermal expansion tank may be required, check local codes.
  5. When using optional factory mounted pump, max pipe length 30' total, 6-90° elbows, full pipe size.
  6. **CAUTION: PUMP SIZING MUST BE BASED UPON WATER HARDNESS AT JOB SITE.**
  7. Common piping must be sized for maximum combined heater flow.
- \*Grooved Piping System

Notice: This drawing shows suggested piping configuration and valving.  
Check with local codes and ordinances for additional requirements.

**WATER CATEGORY**

S = Soft	1 Through 7.9
N = Normal	8 Through 18
H = Hard	> 18.1
Grain Hardness Per Gallon = PPM ÷ by 17.1	