



260 North Elm Street - Westfield, MA 01089
413.568.9571 fax 413.568.1178

ONE HEATER SINGLE PASS ONE HORIZONTAL TANK

Domestic Piping D-13

Heater connection Pipe Sizing and Heat Exchanger Configuration

Heater Model	Pipe size NPS	Configurations
2000-4000	4"	Single Pass

- Pump
- Gate Valve
- Globe Valve
- Angle Valve
- Butterfly Valve
- Circuit Setter
- Ball Valve
- Motorized Valve
- Solenoid Operated Valve
- Self-Operated Valve
- Pressure Reducing Valve
- Check Valve
- Pressure Relief Valve
- Flow Switch
- Thermometer
- Aquastat Union
- Pressure Switch
- Gas Pressure Regulator
- Automatic Air Vent

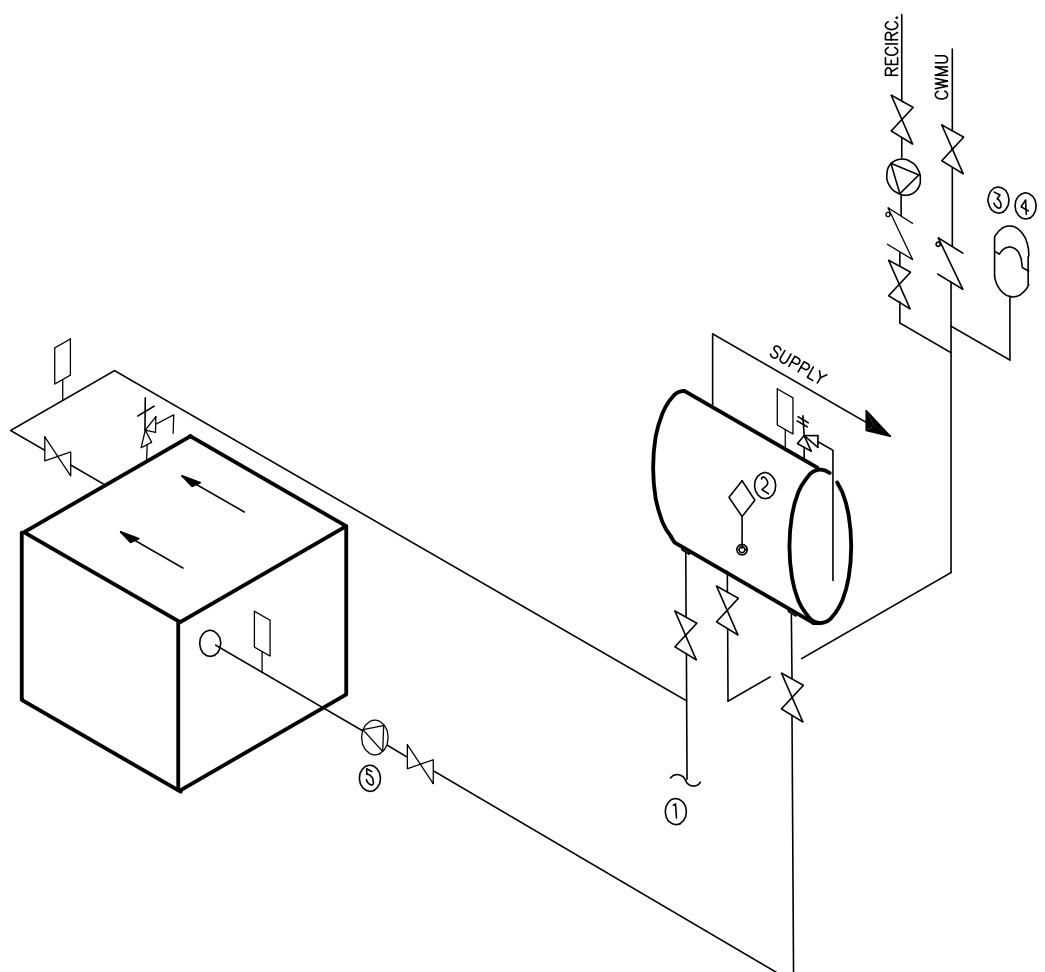

NOTES:

1. Optional CWMU & Recirc. line location.
 2. When using intermittent pump and pump delay, locate remote aquastat well in lower 1/3 of tank with heat sensing compound.
 3. Back flow preventer may be required, check local codes.
 4. Thermal expansion tank may be required, check local codes.
 5. When using optional factory mounted pump, max pipe length 30' total, 6-90° elbows, full pipe size.
 6. **CAUTION: PUMP SIZING MUST BE BASED UPON WATER HARDNESS AT JOB SITE.**
 7. Common piping must be sized for maximum combined heater flow.
- *Grooved Piping System

Notice: This drawing shows suggested piping configuration and valving.
Check with local codes and ordinances for additional requirements.

WATER CATEGORY

S = Soft	1 Through 7.9
N = Normal	8 Through 18
H = Hard	> 18.1
Grain Hardness Per Gallon = PPM ÷ by 17.1	