



Domestic Hot Water Heaters and Boilers



8900 SERIES



RELIABLE DOMESTIC HOT WATER AND HYDRON- IC SPACE HEATING.

RBI 8900 Series atmospheric combustion units offer thermal efficiencies of 81% and are the most durable and serviceable boilers on the market. They offer a wide 420 to 1,900 MBH size range for applications from car washes to office buildings. All models come with intermittent pilot ignition, adjustable high limit, 24V gas valve with either single-stage or two-stage firing. A motorized gas valve for modulation firing is also available.

STANDARD EQUIPMENT

- Bronze headers for hot water supply
- Cast iron headers for hydronic heating
- Field reversible headers
- 2-Pass finned copper tube heat exchanger, national board certified 160 psi ASME
- Slide out heat exchanger for easy and economic maintenance
- ASME pressure relief valve, mounted
- 2 1/2" interlocking combustion chamber
- Built-in, integral draft diverter single flue opening
- Flow switch mounted and wired
- Inlet & outlet thermometers
- 110/24 volt transformer
- High limit control with manual reset
- Electronic intermittent pilot ignition
- Single phase pump delay

OPTIONAL EQUIPMENT

- Single pass heat exchanger
- Two-stage, four-stage, or modulating firing modes
- Flame safeguard ignition with motorized gas valves and 110V controls
- Keyboard display module S7800A
- Dual flue outlet
- Power venter
- High & low gas pressure switches
- Cupro nickel heat exchanger
- Low water cut-off
- Tekmar® BTC control for staged firing
- Alarm for flame failure with silencing switches

SMART SERVICE DESIGN

Ease of installation and service are trademarks of all RBI water heaters and boilers. Critical components are fully accessible, including slide out burner tray and heat exchanger to make short work of service and maintenance calls. Inspection and replacement of combustion chamber by simple removal of end panel and end refractory can be done in less than 15 minutes. All major components can be inspected or removed without disturbing boiler casing or breaching.

- Slide Out Heat Exchanger.
- Up Front 24 Volt Controls.
- Slide Out Burner Tray.
- 2 1/2" Interlocking Castable Refractory for added strength and higher insulation value.
- All Major Components can be inspected or removed without disturbing boiler casing or breaching.
- Gas and water connections from either the left or right hand side of unit.
- Field reversible headers.

DEPENDABLE, EFFICIENT PERFORMANCE

- 81% efficient
- Heavy duty structural steel frame
- 16 or 18 gauge sheet metal components
- 2 1/2" interlocking castable refractory for added strength and higher insulation value
- 5-Year heat exchanger warranty, hot water supply boilers
- 10-Year heat exchanger warranty, hydronic heating boilers

DIMENSIONS AND RATINGS

Model	Input		Output		Net I=B=R		Flue Vent				Dual Exhaust Vent		Connections		
	MBH	kW	MBH	kW	MBH	kW	Dim. A		Dim. B		Dim. C		Gas		Water
							In.	mm	In.	mm	In.	mm	Nat.	LP	In.
420	420	123	340	100	293	86	28½	724	10	254	–	–	1	1	2½
530	530	155	429	125	370	108	33	830	10	254	–	–	1	1	2½
630	630	185	510	150	440	129	37½	952	12	305	–	–	1	1	2½
735	735	215	595	174	513	150	42	1056	14	355	–	–	1	1	2½
840	840	246	680	199	586	172	46½	1181	14	355	10	254	1	1	2½
950	950	278	770	226	664	195	51	1295	14	355	10	254	1	1	2½
1050	1050	308	851	249	734	215	55½	1409	16	406	12	305	1	1	2½
1160	1160	340	940	275	810	237	60	1524	16	406	12	305	1	1	2½
1260	1260	369	1021	299	880	258	64½	1638	16	406	12	305	1¼	1	2½
1370	1370	402	1110	325	957	280	69	1752	18	457	14	355	1¼	1	2½
1470	1470	431	1191	349	1027	301	73½	1867	18	457	14	355	1¼	1¼	2½
1580	1580	463	1280	375	1103	323	78	1981	18	457	14	355	1¼	1¼	2½
1685	1685	494	1365	400	1177	345	82½	2095	18	457	14	355	1¼	1¼	2½
1790	1790	525	1450	425	1250	366	87	2210	20	508	16	406	1½	1½	2½
1900	1900	557	1539	451	1327	389	91½	2324	20	508	16	406	1½	1½	2½

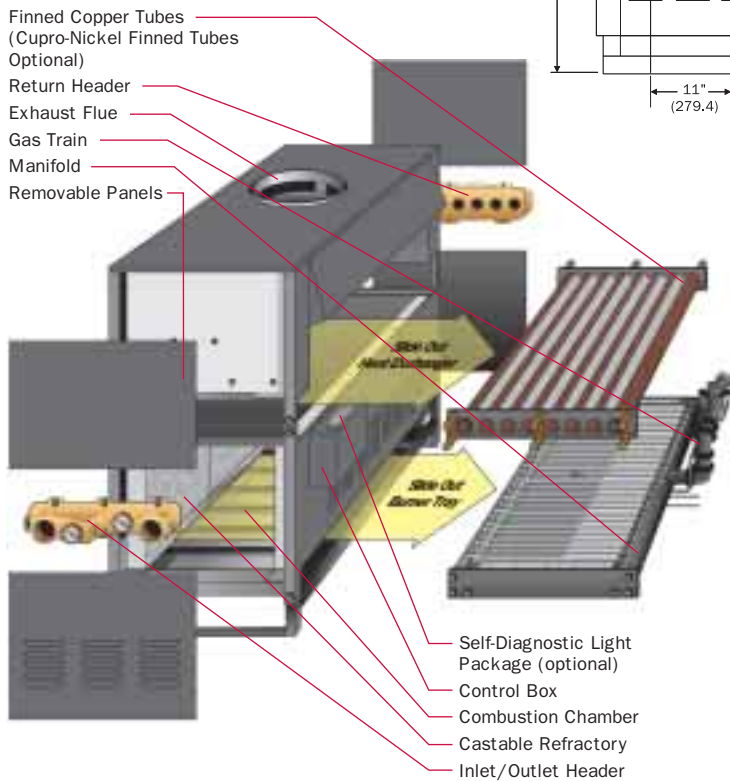
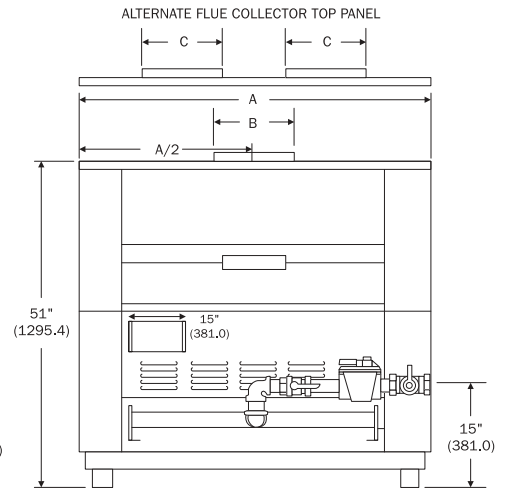
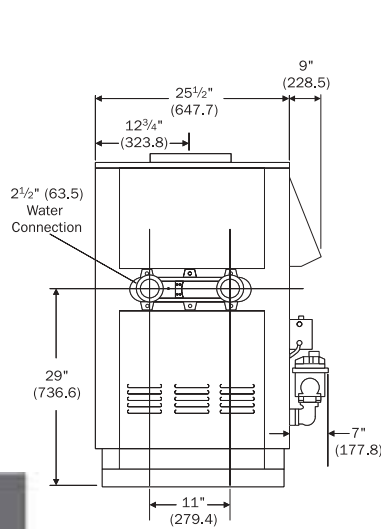

NOTES:

- Minimum Clearance from Combustible Material is: 20" top, 45" front, 24" back and 24" side.
- Minimum Frontal Clearance for Burner Service is 30".
- Dimensions in parenthesis are in millimeters.



MEA#117-96-E

RECOVERY CAPACITY ΔT (GPH & LPH)

Model	40° F	22° C	60° F	33° C	80° F	44° C	100° F	56° C	120° F	67° C	140° F	78° C
420	1021	3866	681	2578	511	1935	408	1545	340	1287	292	1106
530	1288	4876	859	3252	644	2438	515	1950	429	1624	368	1393
630	1532	5800	1021	3866	766	2900	613	2321	511	1935	438	1658
735	1787	6766	1191	4509	893	3381	715	2707	596	2256	511	1935
840	2042	7731	1361	5153	1021	3866	817	3093	681	2578	583	2207
950	2309	8742	1540	5830	1155	4373	924	3498	770	2915	660	2499
1050	2553	9666	1702	6444	1276	4831	1021	3866	851	3222	729	2760
1160	2820	10677	1880	7118	1410	5338	1128	4271	940	3559	806	3052
1260	3063	11597	2042	7731	1532	5800	1225	4638	1021	3866	875	3313
1370	3330	12607	2220	8405	1665	6304	1332	5043	1110	4202	952	3604
1470	3574	13531	2382	9018	1787	6766	1429	5410	1191	4509	1021	3866
1580	3841	14542	2561	9696	1920	7269	1536	5815	1280	4846	1097	4153
1685	4096	15507	2731	10340	2048	7754	1638	6201	1365	5168	1170	4430
1790	4351	16473	2901	10983	2176	8238	1741	6591	1450	5490	1243	4706
1900	4619	17488	3079	11657	2309	8742	1848	6997	1540	5830	1320	4998

HEAT EXCHANGER HEAD LOSS & TEMPERATURE RISE

Model	20° F				25° F				30° F				35° F			
	GPM	l/s	ΔP Ft	KPa	GPM	l/s	ΔP Ft	KPa	GPM	l/s	ΔP Ft	KPa	GPM	l/s	ΔP Ft	KPa
420	34.0	2.1	0.6	1.8	—	—	—	—	—	—	—	—	—	—	—	—
530	42.9	2.7	1.0	3.0	34.3	2.2	0.6	1.9	—	—	—	—	—	—	—	—
630	51.0	3.2	1.6	4.7	40.8	2.6	1.0	3.0	34	2.1	0.7	2.1	—	—	—	—
735	59.5	3.8	2.5	7.4	47.6	3.0	1.6	4.7	39.7	2.5	1.1	3.3	34.0	2.1	0.6	1.8
840	68.0	4.3	3.4	10.1	54.4	3.4	2.2	6.5	45.3	2.9	1.5	4.5	38.9	2.4	1.3	3.9
950	77.0	4.9	4.5	13.5	61.6	3.9	2.9	8.6	51.3	3.2	2.0	6.0	44.0	2.8	1.5	4.5
1050	85.1	5.4	6.1	18.2	68.1	4.3	3.9	11.6	56.7	3.6	2.7	8.1	48.6	3.1	1.8	5.4
1160	94.0	5.9	7.7	22.9	75.2	4.7	4.9	14.6	62.7	4.0	3.4	10.2	53.7	3.4	2.5	7.4
1260	102.1*	6.4	9.5	28.3	81.7	5.2	6.0	18.1	68.1	4.3	4.2	12.6	58.3	3.7	3.3	9.8
1370	111.0*	7.0	11.7	35.0	88.8	5.6	7.5	22.4	74.0	4.7	5.2	15.6	63.4	4.0	4.0	11.9
1470	119.1*	7.5	14.2	42.4	95.2	6.0	9.1	27.1	79.4	5.0	6.3	18.9	68.1	4.3	4.9	14.6
1580	128.0*	8.1	17.1	51.1	102.4*	6.5	10.9	32.7	85.3	5.4	7.6	22.8	73.1	4.6	5.8	17.2
1685	—	—	—	—	109.2*	6.9	13.0	38.8	91.0	5.7	9.0	30.6	78.0	4.9	7.2	21.4
1790	—	—	—	—	116.0*	7.3	15.3	45.6	96.6	6.1	10.6	32.4	82.9	5.2	8.1	24.1
1900	—	—	—	—	123.1*	7.9	16.3	48.7	102.6*	6.5	11.3	33.9	87.9	5.5	9.4	28.0

* Exceeds manufacturers recommended flow rate, use a greater temperature rise or consult manufacturer.

SHIPPING WEIGHT

Model	lbs.	kg.
420	534	240
530	555	250
630	590	266
735	630	284
840	680	307
950	742	334
1050	806	363
1160	853	384
1260	887	400
1370	912	411
1470	987	445
1580	1040	469
1685	1078	486
1790	1145	516
1900	1108	500

In the interest of product improvement, RBI reserves the right to make changes without notice.



1300 Midway Blvd., Mississauga, Ontario L5T 2G8
Tel. (905) 670-5888 Fax (905) 670-5782

260 North Elm Street, Westfield, MA 01085
Tel. (413) 568-9571 Fax (413) 568-9613

NOTE: The 8900 Series are Category I appliances and must be vented into a negative pressure vent system.